

LH-SS&SL Hanger Mounts

LIVA-EP
利瓦环保

Feature:

- ★ Spring diameter shall be not less than 0.8 times the compressed height of the spring at the design load. Springs shall have a minimum additional travel to solid equal to 50 percent of the actual deflection.
- ★ Neoprene bushing for upper mounting rod
- ★ With deflection scale
- ★ Fail safe design.
- ★ Noise and vibration isolation.
- ★ Maintenance free .
- ★ Wide load range available

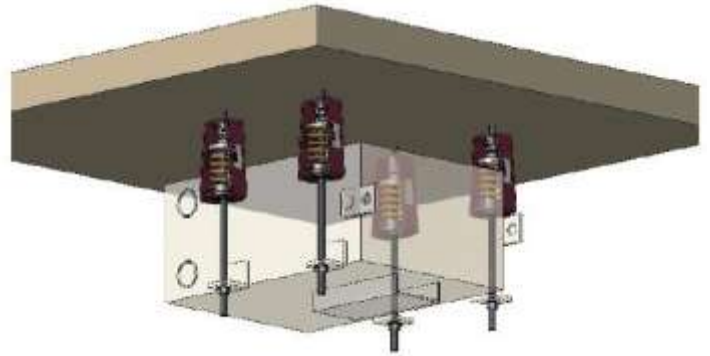

Applications:

- ★ Hanging ceilings、 HVAC ducting networks、 Other suspension applications

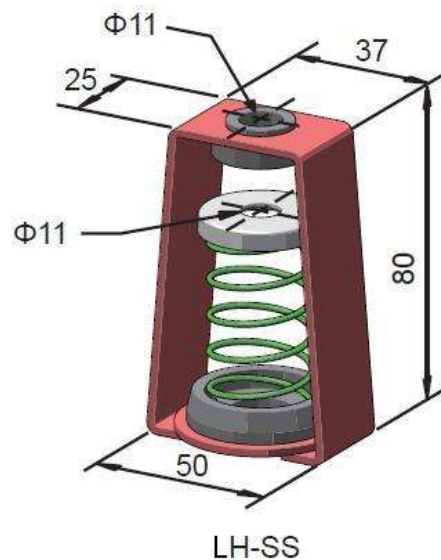
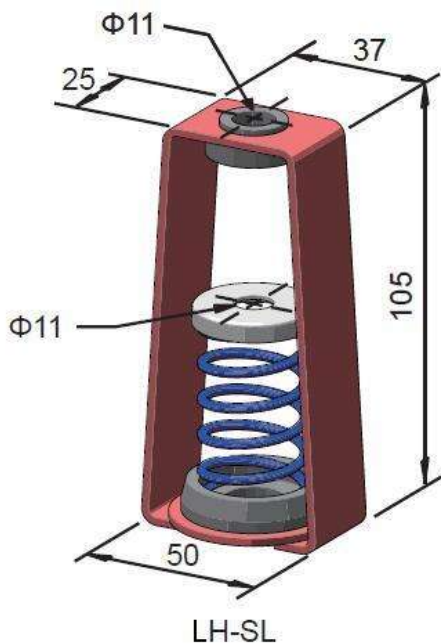

Type	Spring rate KG/mm	Rated Defl. mm	Rated Capacity KG	Color Code
LH-150-SS	0.6	25	10~15	Blue
LH-025-SS	1.0	25	15~25	Dark Green
LH-150-SL	0.6	25	10~15	Blue
LH-025-SL	1.0	25	15~25	Dark Green